

Data sheet EN U005 INTEGRA-pw fastening set

INTEGRA-pw safety barrier

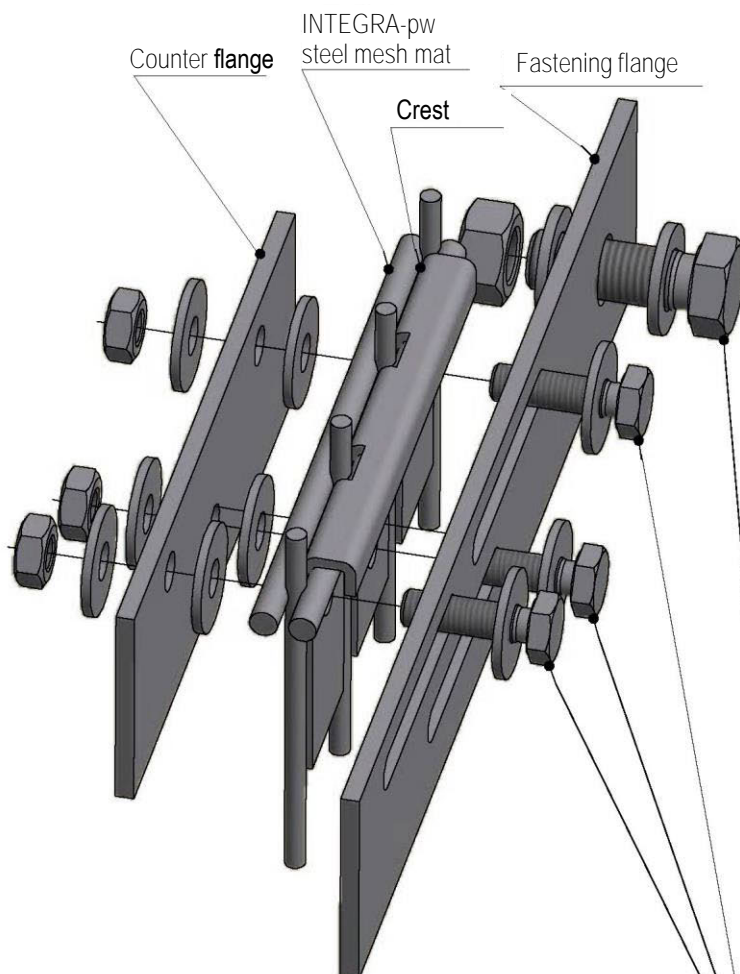

1x hexagon **bolt** ISO 4017 - M10 - 8.8 - galvanised
 3x washer ISO 7093 - \varnothing 10.5 - galvanised
 1x hexagon nut ISO 4032 - M10 - galvanised

1x hexagon **bolt** ISO 4017 - M16 - 8.8 - galvanised
 2x washer ISO 7089 - \varnothing 17 - galvanised
 1x hexagon nut ISO 4032 - M16 - galvanised

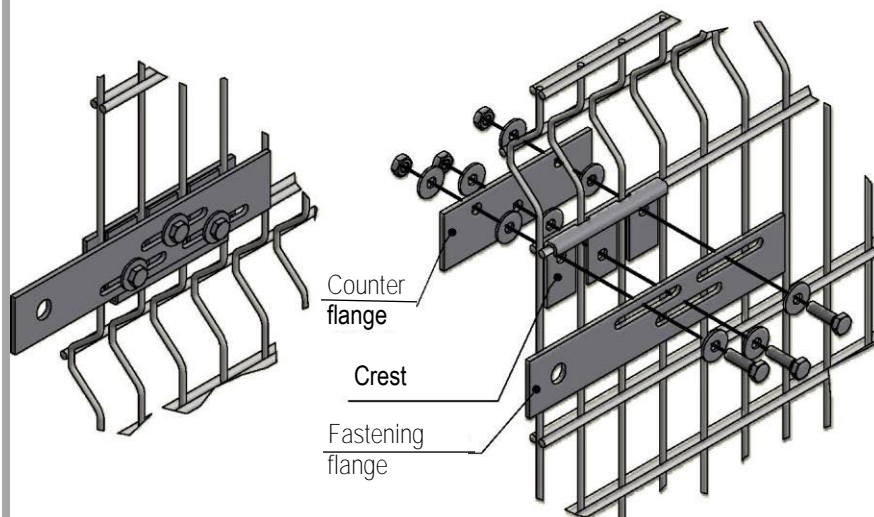

Note:

Fastening flange length: 310 mm

Tightening torques for bolts:

M10 = 30 Nm

M16 = 100 Nm

During assembly, ensure that the tightening torques are applied using a calibrated torque wrench. Make sure that the numbers embossed on the nuts are still visible after they have been fastened.

DIBt AbZ
 INTEGRA-pw
 Z-14.7-882